

rūke knit



┆ Since 2011 ┆ 

AUTUMN HOODED CARDIGAN

┆ Feminine ┆ Simple ┆ Stylish ┆

Autumn hooded cardigan knitting pattern

The Autumn Hooded Cardigan is a hip-length design with long balloon sleeves finished with ribbed cuffs. It is worked from the top down and features a boat neckline. The front band, with 11 buttons, is worked in one piece together with the cardigan, which means very little finishing is needed. The hood is worked after the cardigan is complete. The cardigan has a clean, minimal look with smooth Stockinette stitch and a relaxed silhouette. The hood sits softly around the neck and adds a casual, comfortable touch to the design. Wide ribbing at the hem gives the cardigan structure and creates a neat finish. The simple shape and timeless style make it a versatile garment for everyday wear. Autumn Hooded Cardigan is an easy-to-style piece that pairs beautifully with jeans and boots.

Sizes:

XS (S) M (L) XL (2X) 3X (4X) to be worn with 20 cm (8 in) positive ease. Shown in size L.

Yarn:

Filcolana, Peruvian highland wool (100% virgin wool; 50 g (1.75oz) = 100m (109yds)).
Colour: 973.

Yarn weight (Worsted / Afghan / Aran):

600 (600) 650 (650) 700 (700) 750 (750) g
21.1 (21.1) 22.9 (22.9) 24.6 (24.6) 26.4 (26.4) oz
12 (12) 13 (13) 14 (14) 15 (15) balls
1200 (1200) 1300 (1300) 1400 (1400) 1500 (1500) m
1308 (1308) 1417 (1417) 1526 (1526) 1635 (1635) yds

Needles:

4 mm (US6, UK8) 40-60-80 cm (16-24-31 in) circular needles and 4 mm (US6, UK8) 20 cm (7.75 in) 4 pcs. double point needles.

Gauge:

10 cm x 10 cm (4 in x 4 in) = 17 stitches x 26 rows in Stockinette stitch after washing.

Notions:

10 closed stitch markers, 2 pieces of contrasting yarn of 50 cm length each, tapestry needle, sewing needle, 11 pcs. buttons Ø 15 mm (0.5 in).

Finished measurements

	XS	S	M	L	XL	2X	3X	4X
Bust circumference, cm	116.5	119.0	126.0	133.0	140.0	147.0	154.0	161.0
Bust circumference, in	46.50	47.50	50.25	53.25	56.00	58.75	61.75	64.50
Sweater length (center back), cm	47.5	49.0	50.5	52.0	53.5	55.0	56.5	58.0
Sweater length (center back), in	19.00	19.50	20.25	20.75	21.50	22.00	22.50	23.25
Sleeve length (from neck), cm	62.5	64.0	66.0	67.5	69.0	70.5	72.0	73.5
Sleeve length (from neck), in	25.00	25.75	26.25	27.00	27.50	28.25	28.75	29.50
Sleeve upper arm girth, cm	30.0	30.5	33.0	36.0	39.0	41.0	44.0	47.0
Sleeve upper arm girth, in	12.00	12.25	13.25	14.25	15.50	16.50	17.75	18.75

Abbreviations

<https://www.rukeknit.com/knitting-abbreviations>



K knit

P purl

RLI With the right needle raise right leg of bottom stitch onto the left needle and knit. [1 stitch increased]

Video how to work RLI: <https://youtu.be/FidHxFG1sKI>



LLI Lift the left leg of the stitch 2 rows below the stitch on right-hand needle onto left-hand needle and knit it through the back loop. [1 stitch increased]

Video how to work LLI: <https://youtu.be/KToBy8j2RQY>



K2togR Knit next two stitches together so first stitch would be on the top. [1 stitch decreased]

Video: <https://youtu.be/1PgQDyBXuV4>



K2togL Knit next two stitches one at a time so second stitch would be on the top. [1 stitch decreased]

Video: <https://youtu.be/MRHdJo0fwWs>



RS right side

WS wrong side

St(s) stitch(es)

Sl slip

pm place marker

sm slip marker

*.....; **repeat from * to** Work the instructions after * and then repeat that section as instructed

Cardigan schematic

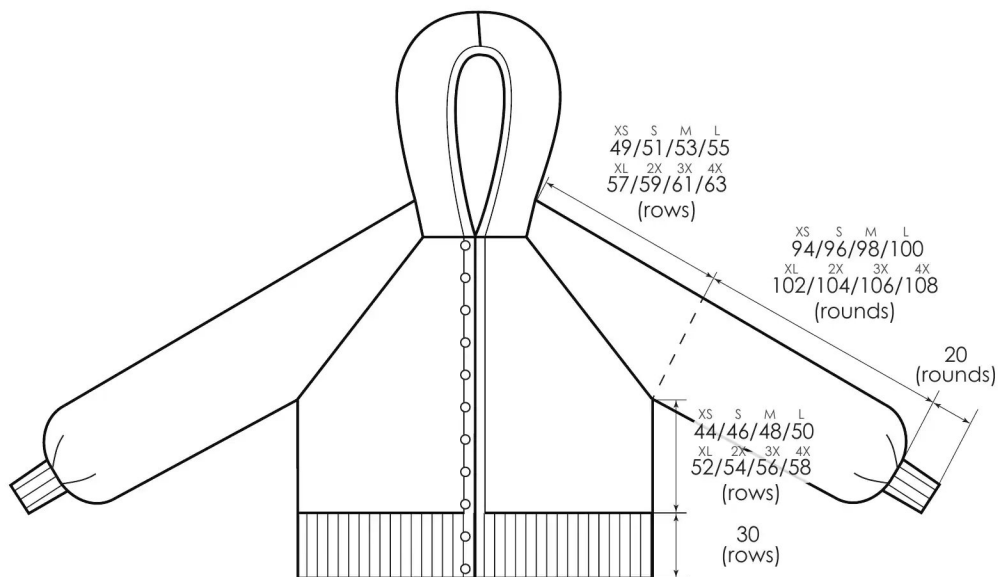

Pattern directions

🌸 Yoke (from neck to armpit)

The yoke is worked flat using 4 mm (US6, UK8) 40-60-80 cm (16-24-31 in) circular needles. Change to longer circular needles as the stitch count increases. This part is worked in raglan shape using RLI and LLI increases and 10 closed stitch markers that separate the raglan stitches and front bands.

Cast on 112 (112) 118 (118) 118 (124) 124 (124) sts.

Video of cast-on: https://youtu.be/ljol5n_ydhs



Row 1 (WS) Sl1, p1, k1, p1, k1, pm, p18 (18) 19 (19) 19 (20) 20 (20), pm, p2, pm, p9 (9) 10 (10) 10 (11) 11 (11), pm, p2, pm, p40 (40) 42 (42) 42 (44) 44 (44), pm, p2, pm, p9 (9) 10 (10) 10 (11) 11 (11), pm, p2, pm, p18 (18) 19 (19) 19 (20) 20 (20), pm, k1, p1, k1, p2.

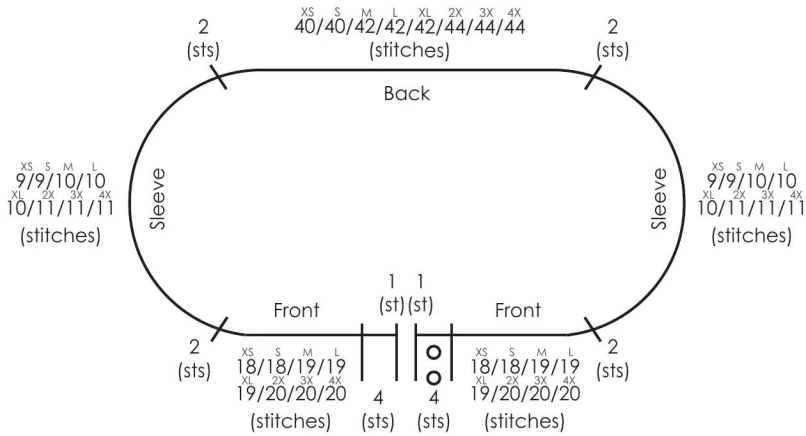

Row 2 (RS) Sl1, k1, p1, k1, p1, sm, k18 (18) 19 (19) 19 (20) 20 (20), RLI, sm, k2, sm, LLI, k9 (9) 10 (10) 10 (11) 11 (11), RLI, sm, k2, sm, LLI, k40 (40) 42 (42) 42 (44) 44 (44), RLI, sm, k2, sm, LLI, k9 (9) 10 (10) 10 (11) 11 (11), RLI, sm, k2, sm, LLI, k18 (18) 19 (19) 19 (20) 20 (20), sm, p1, k2tog, cast on 1 st, k1, p last st. [Increase 8 sts]



Video how to work RLI: <https://youtu.be/FidHxFG1sKI>

Video how to work LLI: <https://youtu.be/KToBy8j2RQY>



Continue working in Stockinette stitch pattern (RS - knit, WS - purl) until 49 (51) 53 (55) 57 (59) 61 (63) rows have been worked, counting from Row 1. In every RS row, work RLI and LLI increases as established in Row 2. At the same time, continue working rib stitch pattern at the beginning and end of every row on both RS and WS. Work buttonholes ("k2tog, cast on 1 st") in every 12th row, counting from Row 2, at the end of the RS row, as established in Row 2. The next buttonhole must be worked in Row 14.

Total amount of stitches after working Yoke: left front - 47 (48) 50 (51) 52 (54) 55 (56) sts, 2 raglan sts, left sleeve - 57 (59) 62 (64) 66 (69) 71 (73) sts, 2 raglan sts, back - 88 (90) 94 (96) 98 (102) 104 (106) sts, 2 raglan sts, right sleeve - 57 (59) 62 (64) 66 (69) 71 (73) sts, 2 raglan sts, right front - 47 (48) 50 (51) 52 (54) 55 (56) sts.

♥ Body (from armpit to bottom)

The body is worked in rows using 4 mm (US6, UK8) 60-80 cm (24-31 in) circular needles. This part is worked in Stockinette stitch pattern (RS - knit, WS - purl).

On the first Body row, with RS facing, place 57 (59) 62 (64) 66 (69) 71 (73) sleeve

stitches on stitch holders on both sides while continuing to work the Body. Add the raglan stitches to the Body. Cast on 4 (4) 6 (10) 14 (16) 20 (24) underarm stitches at each side. At the same time, continue working rib stitch pattern at the beginning and end of every row, and continue working buttonholes.

Total amount of stitches after working the first Body row: 198 (202) 214 (226) 238 (250) 262 (274) sts.

Continue working in Stockinette stitch pattern (RS - knit, WS - purl). At the same time, continue working rib stitch pattern at the beginning and end of every row, and continue working buttonholes until 44 (46) 48 (50) 52 (54) 56 (58) rows have been worked, counting from the first Body row.

Hem

The hem is worked in rows using 4 mm (US6, UK8) 60-80 cm (24-31 in) circular needles. This part is worked in Rib stitch pattern (k1, p1) until 30 rows have been worked, counting from the first Hem row.

Cast off Cut the yarn by leaving 3-4 times longer yarn-tail than the hem circumference and work the Ruke cast-off in rows: Facing RS *thread the same yarn with tapestry needle through the first three stitches, slip the first stitch from left needle; repeat from * until all stitches have been cast off.

Video of Ruke cast off in rows: <https://youtu.be/bl8vlt6vl7w>



Sleeves (from armpit to cuff)

The Sleeve is worked in rounds using 4mm (US6, UK8) 40 cm (16 in) circular needles. Move the sleeve stitches from the holder onto the needles and pick up the same 4 (4) 6 (10) 14 (16) 20 (24) underarm stitches that were cast on previously. The beginning and end of the round is in the middle of these 4 (4) 6 (10) 14 (16) 20 (24) underarm stitches, therefore place a stitch marker in the centre of these 4 (4) 6 (10) 14 (16) 20 (24) stitches.

Video of the Sleeve first round beginning: https://youtu.be/4F_5N3YNHeU

Video of the Sleeve first round end: <https://youtu.be/enLaXgzWqYI>



Total amount of stitches after working Sleeve first round: 51 (52) 56 (61) 66 (70) 75 (80) sts.

Continue working in knit stitches until 83 (85) 87 (89) 91 (93) 95 (97) rounds have been worked, counting from the first Sleeve round.

Next round

Size XS: K17, pm, k17, pm, k17, 2pm.

Size S: K17, pm, k18, pm, k17, 2pm.

Size M: K28, pm, k28, 2pm.

Size L: K20, pm, k21, pm, k20, 2pm.

Size XL: K16, pm, k17, pm, k16, pm, k17, 2pm.

Size 2x: K17, pm, k18, pm, k18, pm, k17, 2pm.

Size 3X: K15, pm, k15, pm, k15, pm, k15, pm, k15, 2pm.

Size 4X: K13, pm, k14, pm, k13, pm, k13, pm, k14, pm, k13, 2pm.

Next round 2 *Knit to 2 stitches before the first stitch marker, k2togL, sm; repeat from * to end, sm. [Decreases: 3 (3) 2 (3) 4 (4) 5 (6) sts]

Video how to work k2togL: <https://youtu.be/MRHdJo0fwWs>



Next round 3 Knit to end and slip markers.

Repeat the last two rounds 4 more times. In the last round, remove all stitch markers except the one which marks the beginning and end of the round.

Total amount of stitches after working the Sleeve: 36 (37) 46 (46) 46 (50) 50 (50) sts.



Cuff

The cuff is worked in rounds using 4 mm (US6, UK8) 20 cm (7.75 in) 4 pcs. double point needles. This part is worked in Rib stitch pattern (k1, p1) until 20 rounds have been worked, counting from the first Cuff round.

Cast off Cut the yarn by leaving 3-4 times longer yarn-tail than the cuff's width and work the Ruke cast-off in rounds:

Thread the tail onto a tapestry needle. With the right side (RS) facing:

1. Insert the needle through the first three stitches on the left needle as if to purl, from right to left.
2. Pull the yarn through all three stitches, but do not drop them off the needle.
3. Slip only the first stitch from the left needle onto the right needle without knitting.
4. Repeat steps 1–3 two more times.
5. Insert the needle through the first three stitches on the left needle as if to purl, from right to left.
6. Slip only the first stitch from the left needle.

7. Repeat steps 5–6 until the entire round is cast off.

Video of Ruke cast off in rounds: <https://youtu.be/eNxQ5sJDS3M>



Repeat the same steps with another sleeve.

Hood

The Hood is worked in rows using 4 mm (US6, UK8) 60 cm (24 in) circular needles. Pick up all 112 (112) 118 (118) 118 (124) 124 (124) cast-on stitches that were cast on at the beginning of the Yoke.

Row 2 (WS) S11, p1, k1, p1, k1, pm, purl to last 5 sts, pm, k1, p1, k1, p2.

Row 3 (RS) S11, k1, p1, k1, p1, sm, *k5, LLI; repeat from * to last 2 (2) 3 (3) 3 (4) 4 (4) sts before st marker, k2 (2) 3 (3) 3 (4) 4 (4), sm, p1, k1, p1, k1, p last st. [Increases: 20 (20) 21 (21) 21 (22) 22 (22) sts]

Video how to work LLI: <https://youtu.be/KToBy8j2RQY>



Row 4 (WS) S11, p1, k1, p1, k1, sm, purl to last 5 sts, sm, k1, p1, k1, p2.

Row 5 (RS) S11, k1, p1, k1, p1, sm, knit to last 5 sts, sm, p1, k1, p1, k1, p last st.

Row 6 (WS) S11, p1, k1, p1, k1, sm, purl to last 5 sts, sm, k1, p1, k1, p2.

Repeat last two rows 4 more times.

Row 15 (RS) S11, k1, p1, k1, p1, *k10, LLI; rep from * to last 2 (2) 9 (9) 9 (6) 6 (6) sts, k2 (2) 9 (9) 9 (6) 6 (6), p1, k1, p1, k1, p last st. [Increases: 12 (12) 12 (12) 12 (13) 13 (13) sts]

Total amount of stitches after working Row 15: 144 (144) 151 (151) 151 (159) 159 (159) sts.

Continue working in Stockinette stitch pattern (RS - knit, WS - purl) and rib stitch pattern band 20 rows more.

Row 36 (WS) S11, p1, k1, p1, k1, sm, p67 (67) 70 (70) 70 (74) 74 (74), pm, p67 (67) 71 (71) 71 (75) 75 (75), sm, k1, p1, k1, p2.

Row 37 (RS) S11 and continue working in pattern as established to 2 stitches before the stitch marker, k2togL, sm, k2togR, continue working in pattern as established to end of row. [Decreased: 2 sts]

Video how to work k2togR: <https://youtu.be/1PgQDyBXuV4>

Video how to work k2togL: <https://youtu.be/MRHdJo0fwWs>



Row 38 (WS) Continue working in pattern as established.

Repeat last two rows 18 more times.

Cast off:

Short row 1 (RS) Continue working in pattern as established to 2 stitches before the stitch marker, k2togL, remove stitch marker, k2togR, turn.

Short row 2 (WS) Sl1, p2tog, turn.

Short row 3 (RS) Sl1, k2togR, turn.

Repeat the last two short rows until the Hood is fully closed. Cut the yarn and weave in the yarn tail.



Finishing

Weaving in all yarn endings is important to prevent the cardigan from unraveling. When washing the cardigan, be sure to use cold or lukewarm water and an ecological detergent that is designed for washing knits. Dry the cardigan flat, avoiding pins or anything that would pin it to the mat. Allow the cardigan to dry naturally for the best results. **Note: The buttons are sewn on after the cardigan has been washed and fully dried, on the Left Front band, aligning with the buttonhole positions.**

Neringa Rūkė © COPYRIGHT 2020 / UPDATED 2026

www.rukeknit.com info@ruke.lt



[@rukeofficial](https://www.instagram.com/rukeofficial)



[rukeofficial](https://www.etsy.com/shop/rukeofficial)



[rukeneringa](https://www.pinterest.com/rukeneringa)

This pattern is for private use only. This pattern may not be copied, sold or otherwise distributed. Products made systematically from this pattern may not be sold. You are welcome to share your version of the AUTUMN HOODED CARDIGAN on Instagram by tagging @rukeofficial on photo or using hasthags

#rukeknit

#iknitrue

#autumnhoodedcardigan

Happy knitting!

